

What's Inside the Package

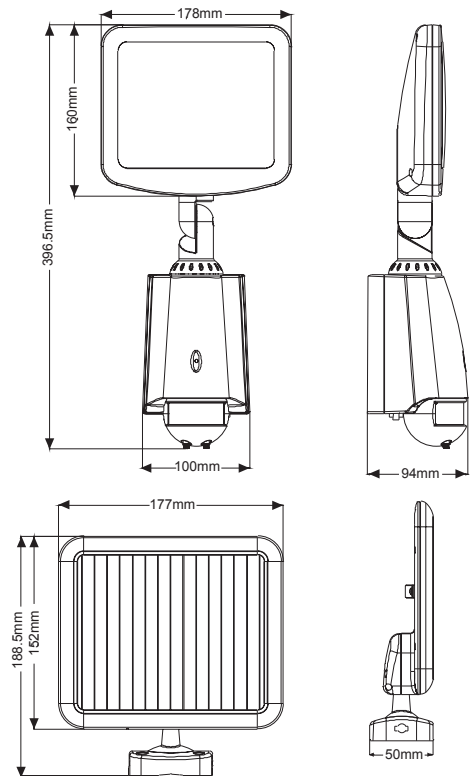

- 80 LED matrix light w/motion detector
- Solar charger board
- User Manual



Note: Packaging items

LED SENSOR LIGHT	1X	Solar panels 10V/2.5W Cord: 5M	1X		8X		8X
				Φ6 Expand screw		4x30 Screw	

Note: Please according to demand a purchase.



Car-mounted Charger
12V Convert 9V



Auto repair lighting



Outdoor camping lighting



Charger
100V-240V Convert 9V

Introduction

Thank you for purchasing **SOLAR POWERED WITH MOTION ACTIVATED 80 LED SECURITY FLOOD LIGHT**

With its effortless setup and lightweight design, the light conforms to all your lighting needs. It was made to provide many years of service using environmentally friendly solar power.

SPECIFICATIONS

- Coverage: 180° sensing angle
- Detection range: 15M (25°C)
- LED single power: 0.06W
- Matrix light: 80 super bright LEDs
- Rated load: 4.7W Max.
- Light-control: <10LUX
- Battery: 7.4V 2000mAH lithium battery
- Solar charger board: 10VDC/2.5W Monocrystalline (with 15' cable) (Life: over 3 years)
- Continuous illumination time: ≥4 hours
- Time delay: Min. 10 seconds, Max. 3 min.
- LED light installation height: 1-3m
- Operation temp.: -10 °C to +40 °C
- luminous flux: 210lm

Important Safety Information

- Do not dispose of battery in fire. This may result in an explosion.
- Do not expose the light to fire or intense heat as the battery may explode.
- Do not immerse in water.
- Never look directly into the light or shine it into another person's eyes.
- Follow proper safety tips to prevent from falling off a ladder.
- Consult your local construction safety guide if needed for installing the light fixture on a building.

One Year Limited Warranty

- This warranty does not apply to damage from misuse or incorrect installation/ connection.
- This warranty does not cover accessories, bulbs, batteries, accidents, alterations, unauthorized use or repair, neglect, misuse, abuse, damages or defects resulting from normal wear and tear (including chips, fading scratches, abrasions or discoloration due to usage or sun exposure), or failure to follow instructions for care and maintenance, fire, flood, and Acts of God.
- This warranty does not include liability for incidental or consequential damages.

Installation Guide

- The light fixture should be installed on a flat and stable surface.
- Avoid placing objects in front of the motion detector that may affect detecting performance.
- Avoid installing the light near an air conditioner, a central heater, or high voltage system.
- Avoid placing the motion detector head toward street traffic or other movements. This will result in a false trigger that will prompt the light to illuminate excessively and drain the battery life.
- Motion detection is most sensitive to movement across the device and less sensitive to motion moving towards or away from it (see pictures below).
- The solar charger board should be set in a sunny area where maximum sunlight can be collected. Typically, the solar board should face a direction (south) where sunlight can charge the board for at least 3 hours per day (5 hours per day if behind glass). It is suggested to charge the light for 24 hours before first use.
- Use a soft wet cloth to periodically (at least once a year) clean the charger board to avoid the reduction of power output due to accumulated dust.

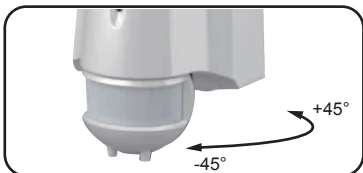

Angle adjustment around

HIGH SENSITIVITY from motion activity coming across the detector.

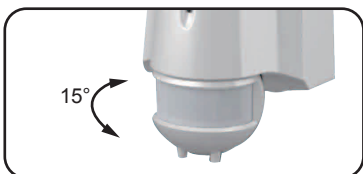

Fluctuation Angle adjustment

LOW SENSITIVITY from motion activity coming towards the detector.

SENSOR INFORMATION

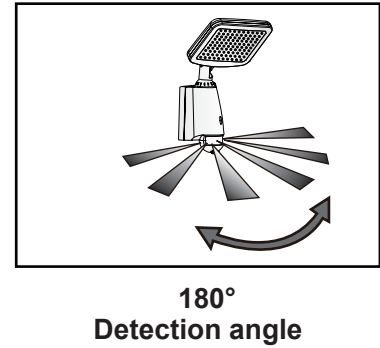
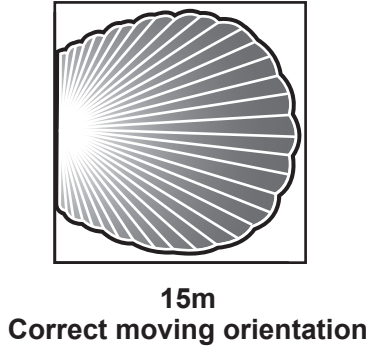
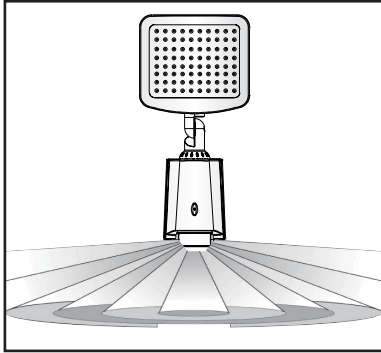

SPECTROGRAM

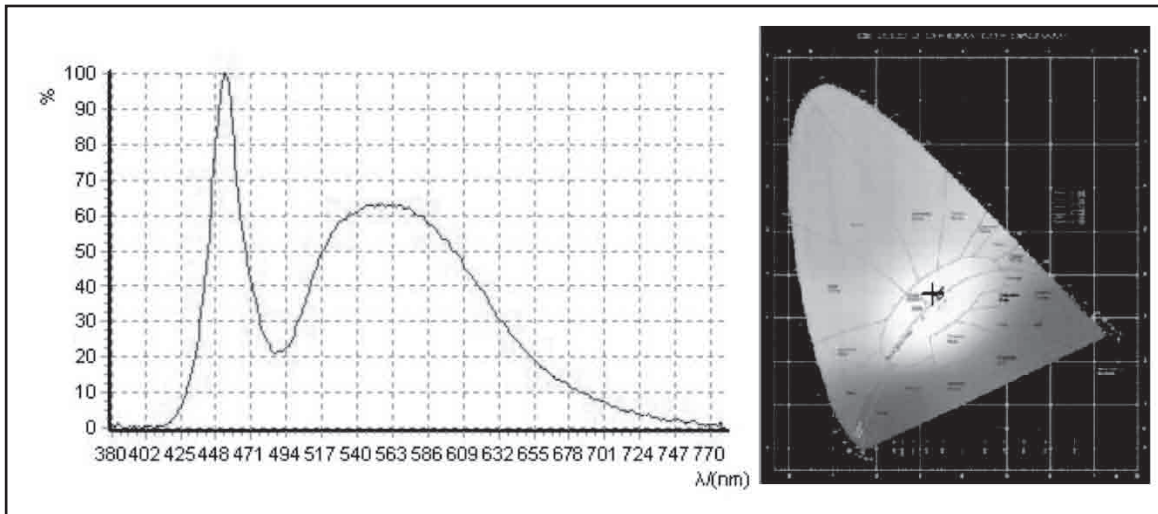

Quick Setup Procedure



Warning!

1. Please keep it away from the children.
2. This product can be installed for outdoor use, but we suggest that against rain/storm & High lights.

Note: Please bring the following tools



Pencil

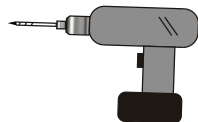

Electric drill

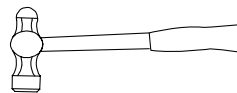

Hammer

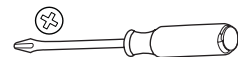

Screwdriver

1. Mark the wall where you wish to mount the light.

2. Drill all four holes.

Place the mount on the wall with nylon anchors (if needed) and screws.

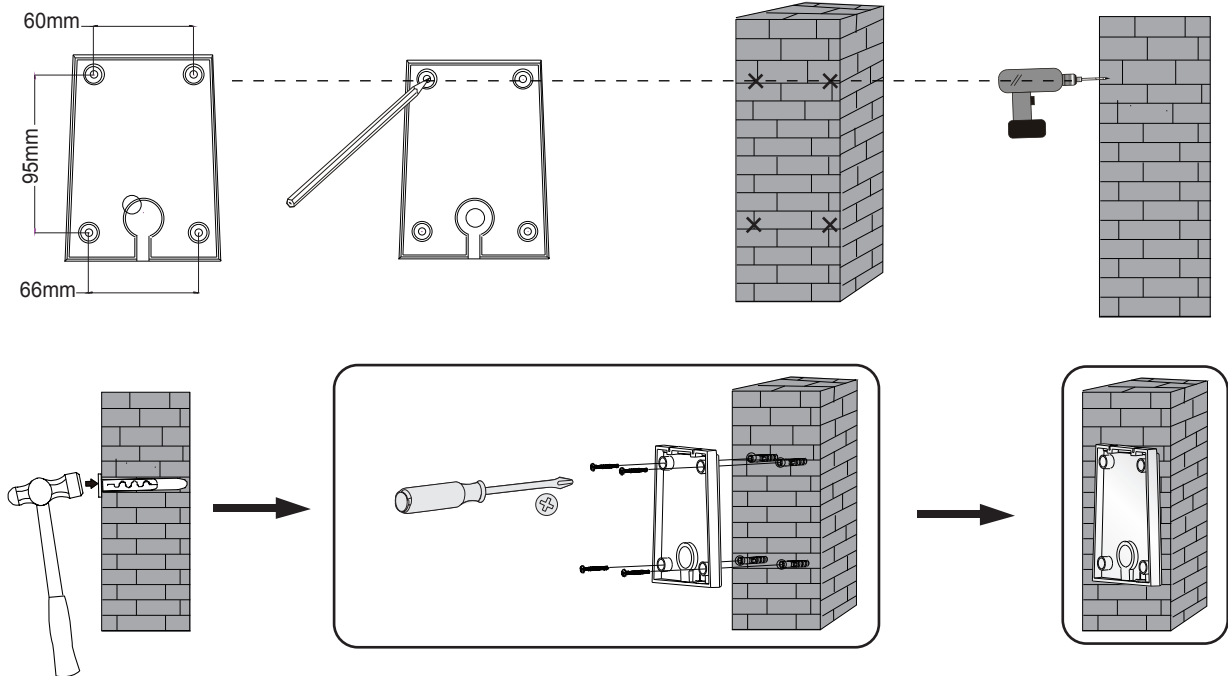

3. Please connect the battery according to diagram in the warning part of the instruction book, and assemble the battery cover as it was.

4. Slide the light into the mount, then screw in the bottom bolt.

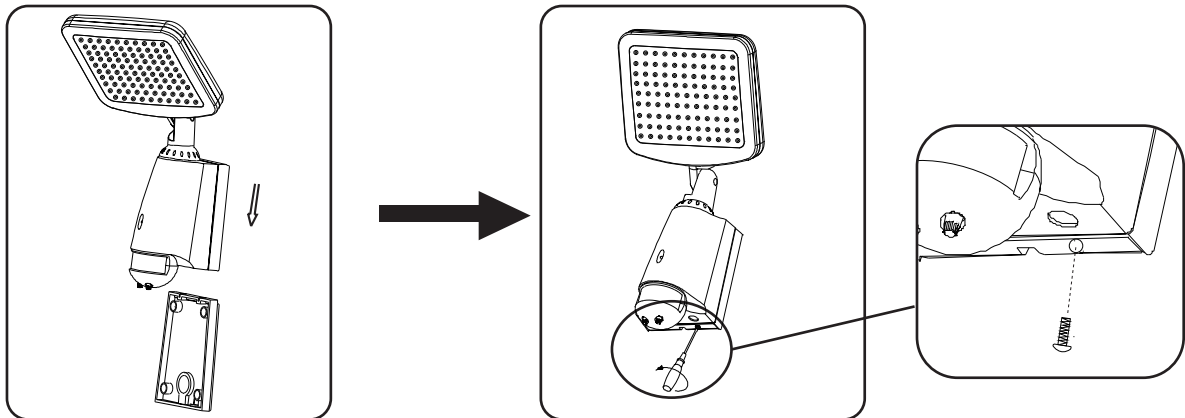

5. Mount solar board with screws. Adjust the direction.

6. Place solar board at a sunny location.

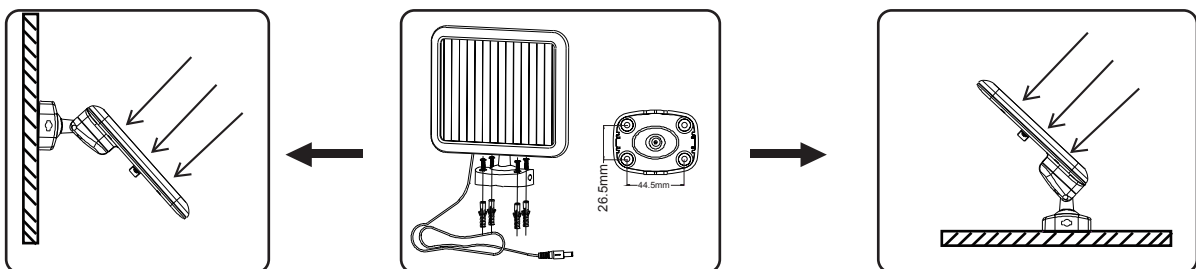

7. Adjust the motion detector direction.

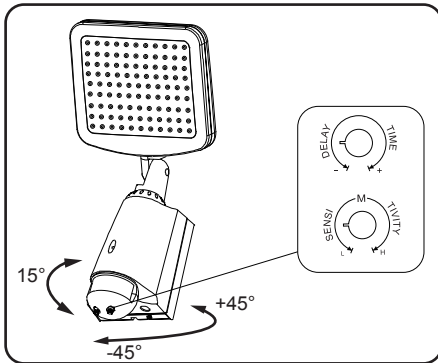

It can be set at the range of 8second (counterclockwise rotation to the end) to 3minute(clockwise rotation to the end) .The timer will recount when the sensor detect a moving signal before the end of the last time, so we advise that you'd better set the time to minimum when you make the detection range testing or the walking testing.

Note: The sensor need to wait 1second to re-work after the light going off. Only after the end of the time, the light will lighten again when detecting the signal.

This range refers to the radii of the circular region that appears on the ground when the light is installed in the 2.5 m height. A minimum detection range (nearly 4 m in radii) rotating a counterclockwise rotation to the end. A maximum detection range (nearly 15 m in radii) rotating a clockwise rotation to the end.

ATTENTION:When use this product, please adjust the sensitivity to an appropriate position you need, please do not adjust the sensitivity to maximum, to avoid the product does not work normally caused by wrong motion.Because the sensitivity is too high easily detect the wrong motion by wind blowing leaves & curtains, small animals, and the wrong motion by interference of power grid & electrical equipment. All those lead the product does not work normally !

When the product does not work normally, please try to lower the sensitivity appropriately, and then test it.

Solutions of prevent the power network pulse interference the products:

Due to the difference of regional interference power network, the pulse of interference is uncertain,so the user are not suggested to adjust the sensitive to the maxium when using.Suggestion:Please install and adjust the sensitive in the appropriate distance using,do not set the maxium sensitivity to prevent misoperation.

8. Adjust the direction of light head.

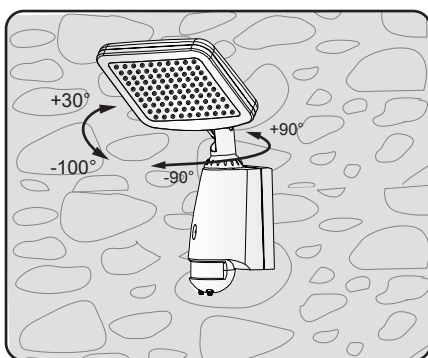

9. Insert the wire plug from the solar board into the bottom of the light.

Make sure the wire plug is completely connected.

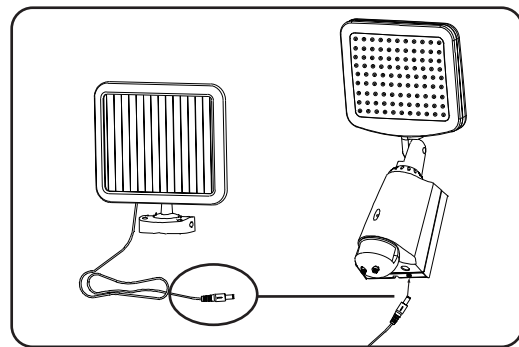

OPERATIONAL GUIDE

1. Battery Installation

Solar LED light, battery voltage 7.4V, 2000MA / H, sensing angle > 150 °, in full lit, continuous working time ≥ 4 hours.

2. Testing Mode:

Before testing, remove the screws in the back, then remove the back cover; connect the battery (2000MA) with the power connectors, the system will be started and the red LED indicate light on; the indication LED light will be off after the system warming up.

3. "OFF" Statuses

The system will be in "power fail safeguard" model. No motion detecting function. Consumes <25UA.

4. "AUTO" Statuses

The system will accept the manual adjustment for "Delay Time" and "Sensitivity".

"Delay time" can be adjusted from 10 seconds to 3 minutes.

"Sensitivity" can be adjusted to 15m(25°C)

The brightness of the LED lights: outside < 10 LUX

When the external ambient light values > 200LUX, the system will shut off PIR sensor;

Power consume: < 3 MA

Electrical current:570~660 MA (when all the lights are fully on)

When the power is lower than <6.4V, the system Turn OFF

When the battery is lower than 6.6V, the LED indication light will be blinking every 30secs for a period of 8 hours ,after 8 hours ,the voltage is not complete to sustain the work.

When the power is lower than <6.2V, the system will enter into the"power shut off "mode,Current<25UA

5. "ON" Statuses

All the lights will be on under the system has been set at "ON".

Electrical current: 500~600MA

When the power is lower than <6.4V, the system Turn OFF

When the battery is lower than 6.6V, the LED indication light will be blinking every 30secs for a period of 8 hours ,after 8 hours ,the voltage is not complete to sustain the work.

When the power is lower than <6.2V, the system will enter into the"power shut off "mode.Current<25UA

6. Oki Management

Impulse voltage is 9V, the maximum electric current is 650MA.

When connected to an external power adapter, LED indicator light will flash once.

Warning!

- 1.When leaving factory,the battery is disconnected. Please connect the battery when using the product.
- 2.When don't use the product or conserve the product for a long time,Please disconnect the battery.

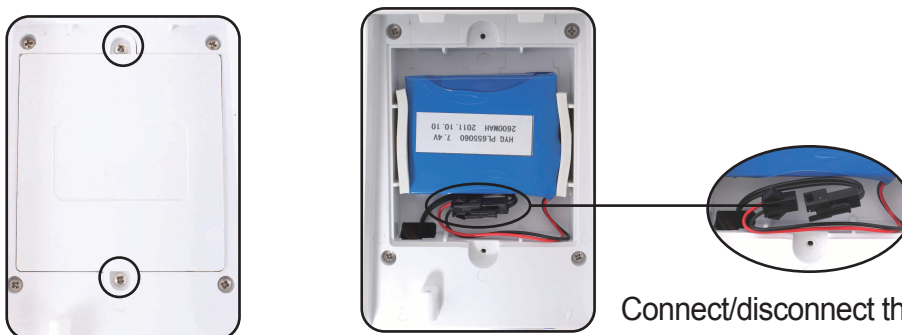

Connect/disconnect the battery connector.

Remove the installation base

Twist off two screws on the battery cover, and then remove the cover.

3. The LEDs in series can function when all the seals are installed in place.
4. Please don't remove or connect with other lamps when powered on.
5. When the LEDs in series are damaged, you need an experienced technician to repair using the same rating LEDs.

Please confirm with professional installation.

Please cut off power supply before installation and removal operations.

Make sure that you have cut off the power for safety purposes.

If improper operation causes losses, the manufacturer does not undertake any responsibility.