

# 50W FLOODLIGHT INSTRUCTION MANUAL



## INSTALLATION



### CAUTION: RISK OF ELECTRIC SHOCK!

WORK MUST BE CARRIED OUT BY AN ELECTRICIAN OR COMPETENT PERSON. IF IN DOUBT, SEEK PROFESSIONAL ADVICE.

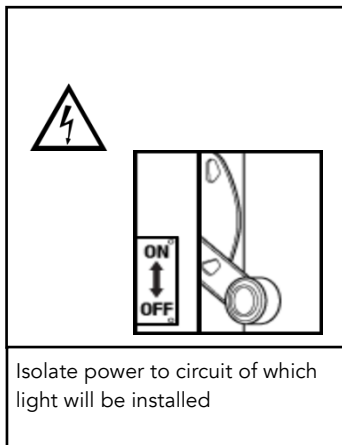

Isolate power to circuit of which light will be installed

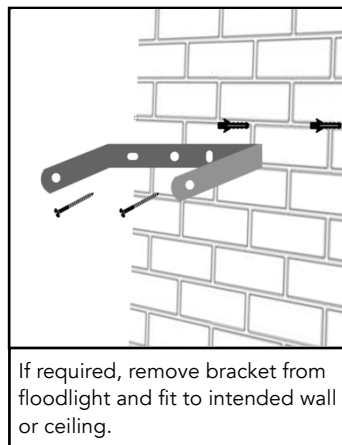

If required, remove bracket from floodlight and fit to intended wall or ceiling.

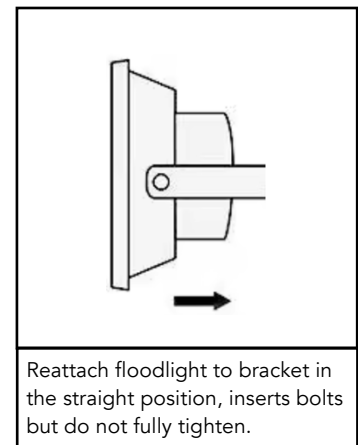

Reattach floodlight to bracket in the straight position, inserts bolts but do not fully tighten.

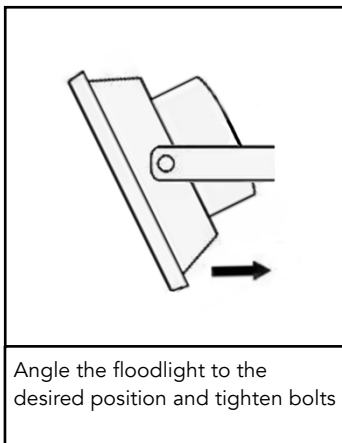

Angle the floodlight to the desired position and tighten bolts

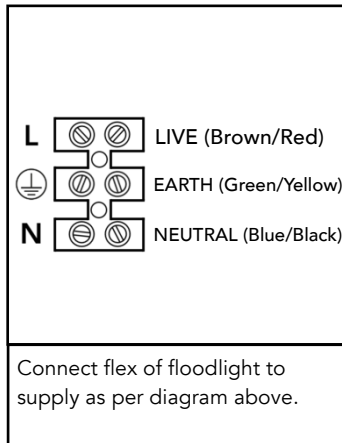

Connect flex of floodlight to supply as per diagram above.

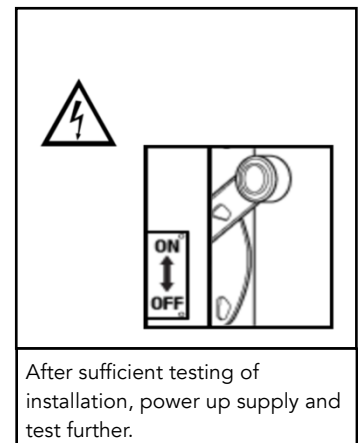

After sufficient testing of installation, power up supply and test further.

## PHOTOCELL VERSION

The built in photocell detects when darkness comes and activates the floodlight, switching the floodlight on. When sunlight arrives, the floodlight will automatically switch off.

Because of the photocell sensor's reactivity to light, it is important to install correctly to avoid sensor to activate at an incorrect time:

- Do not install floodlight with sensor on/near a reflective surface.
- Do not install floodlight with sensor pointing near another light source
- Do not install floodlight with sensor pointing under a shelter/area where sunlight will not hit it.

## PIR SENSOR VERSION

The PIR (Passive Infra-Red) sensor has a sensing device which continuously scans a preset operating zone and immediately switches the lamp on when it detects movement in that area.

To achieve the best results ideally the PIR sensor should be mounted 1.8-2.5m (6-8ft) above the area to be scanned to avoid nuisance triggering, the sensor should be directed away from heat sources such as barbecues, air-con units, other outside lights, moving cars, and flue vents.

Do not aim towards reflective areas such as white walls, swimming pools etc.

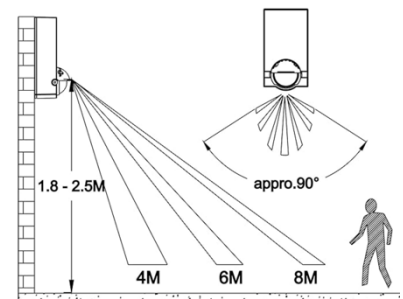

## PIR CONTROLS

Underneath the sensor you will see three dials for the PIR settings:

**TIME:** The length of time that remains switched on after activation is adjustable from (10±5) seconds up to (5±1) minutes. Once the lamp has been triggered by the PIR sensor any subsequent detection will start the timed period again from the beginning.

**SENSITIVITY:** Determines the max. detection distance that the sensor covers. At the max. position, the detection range will be max. 12 meters

**LUX:** The Lux control module has a built-in sensing device (PHOTODIODE) that detects daylight and darkness. Adjustable from daylight to night; it means that the lamp can be turned on after activation in daylight or night according to your setting.

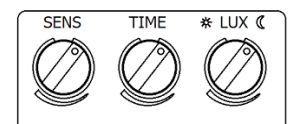

## DISPOSAL

Correct Disposal of This Product (Waste Electrical & Electronic Equipment) (Applicable in the European Union and other European countries with separate collection systems). This marking shown on the product or its literature, indicates that it should not be disposed with other household wastes at the end of its working life. To prevent possible harm to the environment or human health from uncontrolled waste disposal, please separate this from other types of wastes and recycle it responsibly to promote the sustainable reuse of material resources. Household users should contact either the retailer where they purchased this product, or their local government office, for details of where and how they can take this item for environmentally safe recycling. This product should not be mixed with other commercial wastes for disposal.

Voltage	AC220-240V
Wattage	50W
Frequency	50Hz
Light Source	Built in LED
Power Factor	>0.6
Electrical Class	Class I
Installation	Surface
IP Rating	IP65
Dimmable	No
Smart Compatible	No
Materials	Polycarbonate with Glass screen

## MAINTENANCE

The devices are maintenance-free, so never open them. The guarantee becomes void when you open the appliance. Only clean the outside of the devices with a soft, dry cloth or a brush. Prior to cleaning, remove the devices from all voltage sources. Do not use any carboxylic cleaning agents or petrol, alcohol or similar. These damage the surfaces of the devices. Besides, the vapours are hazardous to your health and explosive. Do not use any sharp-edged tools, screw drivers, metal brushes or similar for cleaning. Do not clean this product with a pressure washer.

## GENERAL SAFETY

- Keep all parts out of the reach of children.
- Avoid dropping or shocks; this may damage the electronic circuits.
- Repairs or opening of this item may only be done by an authorized repairer.
- For your safety, always switch off the power supply before changing lamps, adjusting spotlight, heads or cleaning

## HIGH VOLTAGE

- All electrical connections and connection cables must comply with the appropriate rules and match the operating instructions.
- The fitting must be correctly installed if it is to operate reliably. These instructions and the user guide must therefore be studied carefully.
- The electrical supply must be switched off at the consumer unit, preferably by means of a switch in the distribution box, before any installation, maintenance or repair work is undertaken.
- Exterior components must not be installed during rain.
- Take account of the minimal separation distance from other objects and the room required around the fitting.
- If in any doubt consult a professional, taking local installation requirements into account.
- Some countries stipulate that lighting may be installed only by registered installers

## WARRANTY

This product comes with a 2-year warranty (not including lamps). If you have any concerns or questions do not hesitate to contact us.

